



RhinoBond®

INDUCTION FASTENING SYSTEM

**Non-penetrating fastening system
for commercial roofing**

featuring



OWNER'S MANUAL



153 BOWLES ROAD, AGAWAM, MA 01001 USA
800-633-3800 413-789-0252 RHINOBOND.COM

IMPORTANT!
Save this manual
and read it in full
before use.

TABLE OF CONTENTS

3 RhinoBond Tool & System Description

System Components
Power Requirements Chart

3 Safety Instructions

4 Operating Instructions Power Requirements

6 The RhinoBond Display

Display Functions
Menu Options/Features
Error Messages

8 EC Declaration of Conformity

INTRODUCING THE RHINOBOND® SYSTEM

Congratulations! You have in your hands one of the industry's most advanced fastening systems for installing thermoplastic membrane roofing and "approved" clean EPDM membrane*. RhinoBond is a portable, easy-to-use system that secures membrane to roofing substrates using microprocessor-controlled induction welding.

Roofing installed this way has **several benefits:**

- **Creates no point of entry for moisture**
- **Has superior wind uplift resistance**
- **Requires 25–50% fewer fasteners** to meet FM 1-90 and Eurocode National uplift requirements.

The RhinoBond system uses powerful induction technology to create a strong bond between the roofing membrane and fastening plates. The technology that makes this possible, SINCH® Technology, is a compact microprocessor-controlled electromagnetic induction bonding process. Today, this rugged technology is being used to revolutionize industrial and consumer applications.

While RhinoBond is a safe, tested tool, we caution you to be sure that every member of your crew has a thorough understanding of the RhinoBond System before attempting to use it. Read, understand and follow all instructions.

Congratulations on your new purchase. We look forward to your feedback. Please send us your comments and suggestions at any time.

RhinoBond Team

OMG Roofing Products | info@olyfast.com
800-633-3800 | 413-789-0252 | www.rhinobond.com

*Clean EPDM Membrane -- currently there are a limited number of clean EPDM options available only in Europe and approved for use with RhinoBond. Always verify membrane suitability and approvals with membrane supplier. RhinoBond is not suitable for use with other EPDM membrane.

© Copyright 2016 OMG, Inc. All rights reserved.

RhinoBond® and **SINCH Technology®** are registered trademarks of OMG, Inc., a leading provider of innovative fastening solutions and products for the construction industry.

PATENT NOTICE: U.S. Patent Nos. 6,710,314; 6,849,837; 7,399,949; 8,492,683; 8,933,379. Canadian Patent Nos. 2,458,353; 2,602,753. U.S. Patent Pending.

Contact OMG Roofing Products or your roofing membrane manufacturer for the most current list of approvals.



THE RHINOBOND SYSTEM WARRANTY

The RhinoBond System is guaranteed for 200,000 cycles of operation.

During this period OMG, Inc., at its option, will repair or replace any tool for the roofing contractor who originally purchased the tool. This will be done free of charge, provided the tool is determined defective in materials or workmanship upon examination by an Authorized RhinoBond System Service Technician.

This Warranty will be honored only if:

- A. No evidence of abuse, misuse or failure to follow safety or operating instructions, or improper maintenance or modification of the tool, is present. (Read Safety and Operating Instruction Manual for safe use and maintenance instructions.)
- B. When replacement is necessary, the first end-user returns the tool with transportation prepaid, to the nearest Authorized RhinoBond System Service Technician with purchase receipt or other positive proof of purchase.
- C. Only genuine RhinoBond tool, fasteners and plates are used in the application.

THE FOREGOING WARRANTY IS IN LIEU OF ALL OTHER WARRANTIES. ALL OTHER WARRANTIES, WHETHER ORAL, WRITTEN, EXPRESS OR IMPLIED, INCLUDING BUT NOT LIMITED TO THE IMPLIED WARRANTIES OF MERCHANTABILITY AND FITNESS FOR A PARTICULAR PURPOSE SHALL NOT APPLY. THESE OTHER EXPRESS OR IMPLIED WARRANTIES ARE SPECIFICALLY EXCLUDED. BUYER'S OR USER'S REMEDIES ARE SOLELY AND EXCLUSIVELY AS STATED HEREIN. OMG, INC. SHALL IN NO EVENT BE LIABLE FOR INCIDENTAL, CONSEQUENTIAL, INDIRECT OR SPECIAL DAMAGES RESULTING FROM FAILURE OF THIS WARRANTY. IN NO EVENT, WHETHER AS A RESULT OF BREACH OF CONTRACT, WARRANTY, TORT (INCLUDING NEGLIGENCE) OR OTHERWISE, SHALL OMG, INC.'S LIABILITY TO THE BUYER OR USER OF THE TOOL OR ANY LOSS OR DAMAGE ARISING OUT OF THE BREACH OF WARRANTY, CONTRACT OR TORT, EXCEED THE PURCHASE PRICE HEREIN. ANY CLAIM OR LIABILITY SHALL IN ANY EVENT TERMINATE UPON THE EXPIRATION OF THE WARRANTY PERIOD SPECIFIED ABOVE.

For RhinoBond Tool Service:
800-633-3800

THE RHINO BOND SYSTEM

Heat Sinks
(6 included with carrying case)

RhinoBond Tool
with carrying case

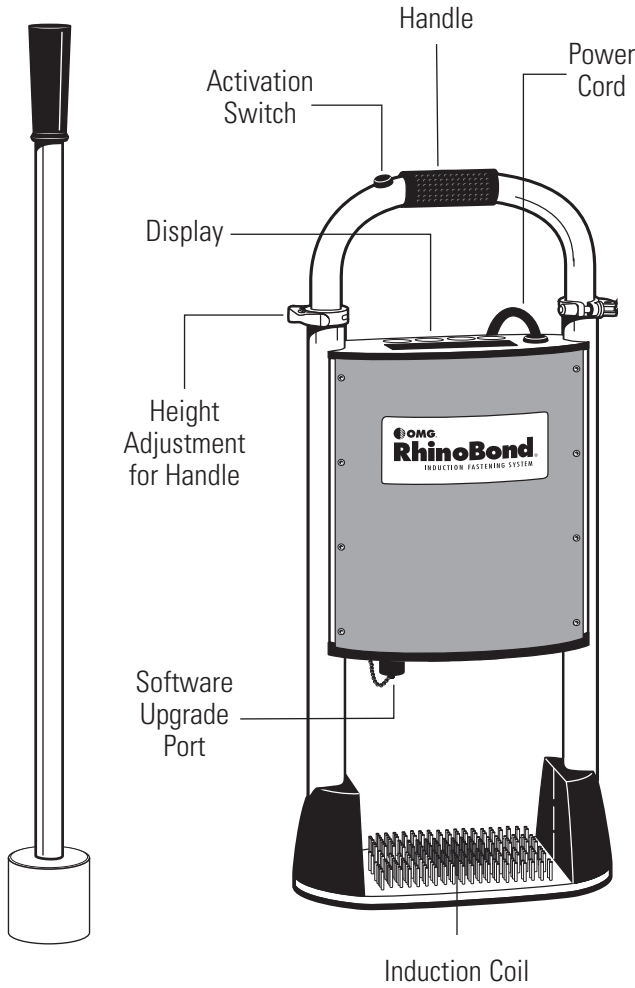

READ & SAVE ALL INSTRUCTIONS

WARNING

The RhinoBond System produces heat that can seriously injure people and damage metal objects. Please be sure that you and your crew members read and understand all instructions in this manual before attempting to use the RhinoBond System. Failure to follow all instructions could result in **property damage, serious personal injury, electric shock or death.**

This appliance is not intended for use by persons (including children) with reduced physical, sensory or mental capabilities, or lack of experience and knowledge, unless they have been given supervision or instruction concerning use of the appliance by a person responsible for their safety. Children should be supervised to ensure that they do not play with the appliance.

DO NOT USE THIS TOOL if you have (or anyone near you has) a **pacemaker, surgical implant, prosthesis or other medical device.** The RhinoBond tool may interfere with proper medical device operation.

DO NOT activate tool over metal objects in/on the floor.

DO NOT use the cord to carry the tool.

UNPLUG THE CORD before attempting to inspect or clean the tool, or you risk electric shock.



DO NOT activate tool over the power cord.



KEEP CORD AWAY FROM heat, liquids, sharp edges and moving parts.



STAY ALERT. Do not use this tool when tired or under the influence of drugs, alcohol or medication that can alter your awareness.



DO NOT allow any object containing metal, such as keys, jewelry, watches etc., within 3 inches (75mm) of the bottom of the tool during use.



IF CORD IS DAMAGED, immediately discontinue using the tool and contact OMG Roofing Products for repair. 800-633-3800



POWER REQUIREMENTS CHART

REGION	USA / CANADA	UK / IRELAND	NETHERLANDS AND REST OF EUROPE	CHINA
POWER REQUIREMENTS	110-120V, 50/60Hz	110-220V / 16A	220-230V / 10A	220V, 50Hz
EXTENSION CORD	12 gauge, 100-ft.	110V, 2.5mm X 30m	16A (230V 3x15), 40m	10A, 30m
PORTABLE GENERATOR POWER SOURCE	5,000W min. with (2) 20A GFCI Circuits	2.5 KVA min. with 16Amp (110V) protected circuit	2.5 KVA min. with 10Amp (230V) protected circuit	Honda EU20i 1.6 KVA w/ 8 Amp (230V) protected circuit
# RhinoBond tools / GENERATOR	2	1	1	1

OPERATING INSTRUCTIONS

STEP 1 INSTALL THE PLATES

Always follow roof system manufacturer's specifications and fastening patterns, or in Europe, distributor wind load calculations and fastening patterns.

When using the RhinoBond tool, it is important to install plates in a straight line. This will improve system performance and help you more easily identify plates under the membrane.

Example:

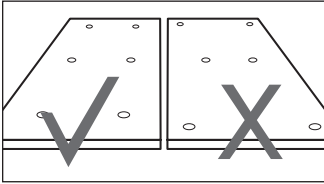

IMPORTANT TIP

Based on roofing manufacturer's fastening pattern, use chalk lines to guide fastener/plate placement.

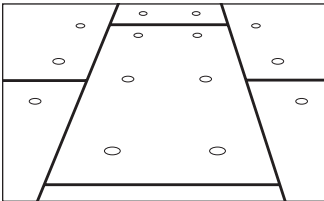

Lay insulation over substrate. Place plates in pattern specified by roofing system manufacturer.

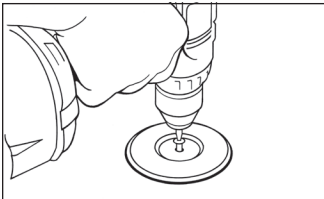

Secure plates using RhinoBond fasteners.

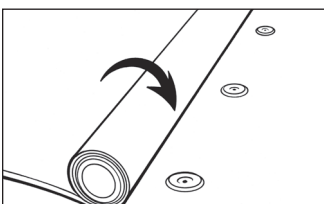

Lay membrane over the plates.

IMPORTANT TIP

Only use fasteners approved for RhinoBond applications. For best installation results, use a variable speed screw gun (2,500 rpm max.). When installing into purlins, use 1,200 rpm max.

WARNING

Do not overdrive fasteners.

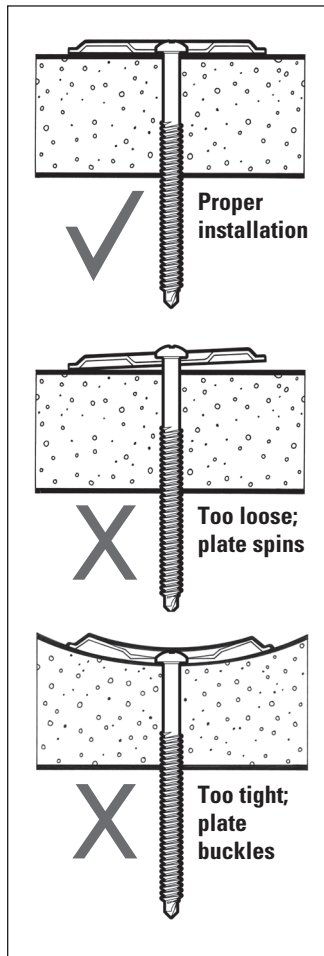

STEP 2 START UP THE RHINO BOND TOOL

WARNING

Failure to follow these instructions may cause damage to your RhinoBond tool.



NEVER start generator with tool plugged in. ALWAYS start generator first, then plug in tool. WHEN NOT IN USE, unplug the tool.

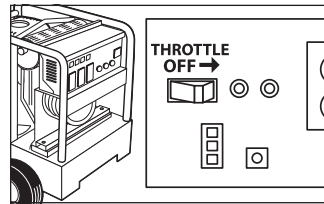

Start portable generator and allow to warm up for 2 minutes. Auto-Throttle, Auto-Idle and/or Eco-Idle switches must be in OFF position.

DEDICATED POWER

No other tools should be plugged into the power source while RhinoBond tools are in operation.

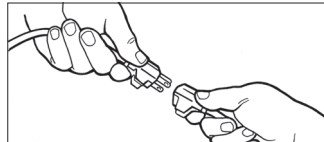

Plug the RhinoBond tool into a stable energy source. Refer to Power Requirements Chart on page 3.

**To remind operators of the importance of Safe Start-Up & Shut Down procedures, there is a warning label on the RhinoBond tool just above the LCD screen.*

STEP 3 CALIBRATE THE RHINO BOND TOOL

Adjust the RhinoBond tool for maximum bond strength based on the ambient temperature (from 0°F/-18°C to 120°F/49°C) and membrane thickness. Adjust the energy level to produce an optimal bond. Start calibration at 0 and test samples at +1, +2, +3, etc.

IMPORTANT TIP

Whenever the ambient temperature changes by 15°F (-9°C), warmer or colder recalibrate the RhinoBond tool.

Use the following calibration process to adjust the energy setting for each tool to the appropriate level for the conditions on the job.

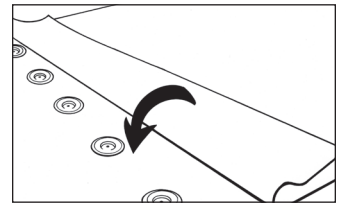

Place 5 plates on a sample of your insulation, 10 inches (250mm) apart. (Do NOT use screws.) Lay a sample of your membrane over the plates.

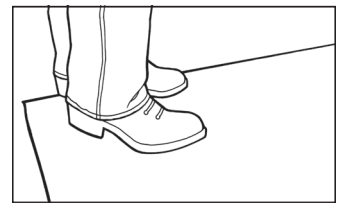

Locate each plate by rubbing the membrane with the sole of your shoe.

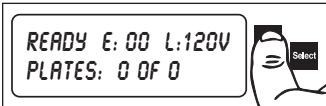

Determine initial energy setting to produce an optimal bond.

Press ▲ or ▼ next to the display to change the energy setting to the appropriate initial setting, then press **Select** to accept the desired setting.

This is a guideline only. EACH tool should be calibrated based on the specific application conditions. If using more than one tool, calibrate each tool individually as proper settings may vary from tool to tool.

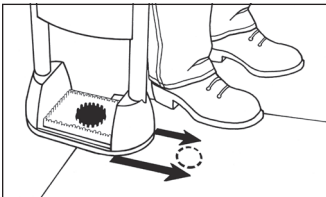

Center red circle of the RhinoBond tool directly over the first plate.

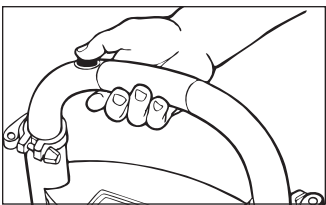

Activate the weld using the activation button on the handle.

WARNING
Do not move RhinoBond tool during cycle.

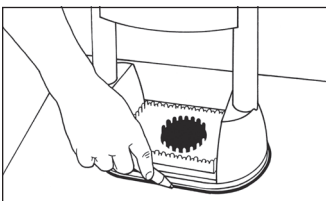

While the RhinoBond is activated (welding), trace around the base of the tool with a grease pencil. This will help you judge your accuracy in centering the coil over the plate.

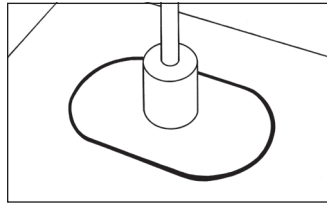

Remove RhinoBond tool after the cycle ends and immediately set a magnetic heat sink directly onto the center of the plate.

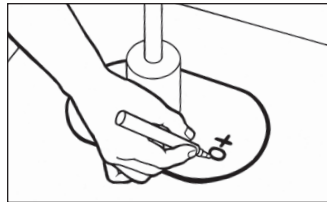

Mark the energy setting next to the plate position with a grease pencil.

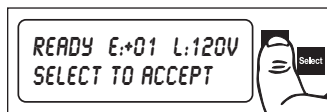

Increase energy setting using ▲ to reach +1 and **Select** to accept the new setting. **Weld the second plate** and trace around it. Immediately place the magnetic heat sink onto the plate and mark this new setting.

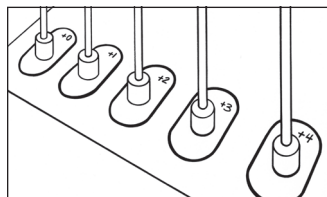

Repeat this process for each plate, increasing the energy +1 unit each time. **Allow plates to cool to the touch completely**, at least 5 minutes, before continuing. Plates should be cool to the touch.

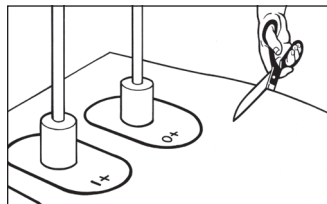

If your calibration sample is attached to the roll of membrane, **cut it off**. A calibration video is available online at www.RhinoBond.com.

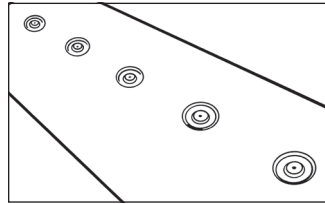

Remove the magnetic heat sinks and turn membrane over to reveal the welded plates.

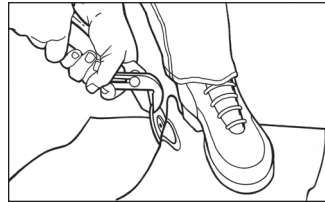

Use pliers to peel each plate off of the membrane.

CALIBRATION TIPS

If a **Low Voltage** message appears in the RhinoBond display or if you do not get a 100% weld during calibration, check power at the end of the cord and determine what else is running on the same circuit.

Power output may be diminished if:

- The cord is too long.
- The power source is overloaded.

BOND RESULTS

PLATE VIEW

MEMBRANE DELAMINATION

TOP OF MEMBRANE

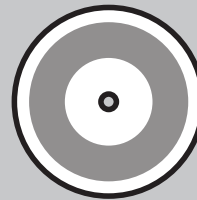

100% BOND

Total, even, consistent 360° adhesion of membrane. Plate makes a visible impression on the top of membrane.

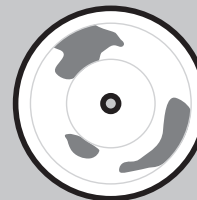

PARTIAL BOND

Uneven/incomplete adhesion of membrane. Energy setting may be too low, tool may be off-center, or plate may be overdriven.

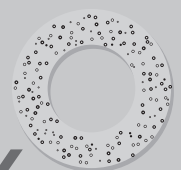

EXCESSIVE HEAT

Membrane may turn yellow, melt or become blistered and adhesive may char.

STEP 4 BOND THE MEMBRANE

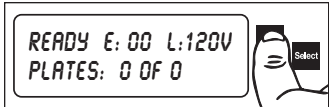

Set tool to level that provides a 100% bond. Several settings may yield a 100% bond. If this happens, select the energy level setting in the middle. See previous page for example of optimal and undesirable bonds.

IMPORTANT TIP

Read **Additional Display Options** on in next section for useful display messages and optional features before proceeding.

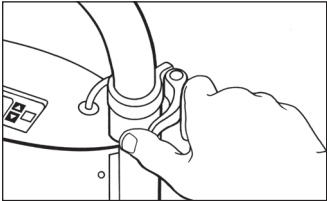

Adjust the handle height, if desired, loosening clamp by twisting to the left, by releasing handle clamps and gently pulling or pushing handle to desired position.

WARNING

Pulling too hard on the handle may damage activation button wires.

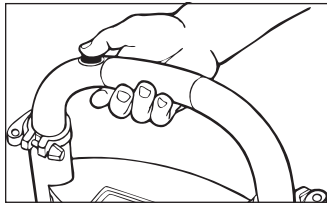
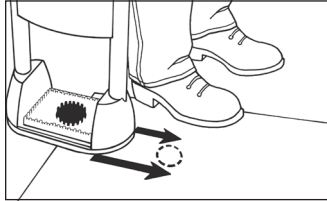

Center the calibrated RhinoBond tool over the first plate in pattern and activate the weld.

WARNING

Tool must be centered over the plate to create a 100% bond. If an error occurs during activation, refer to page 7 for corrective action.

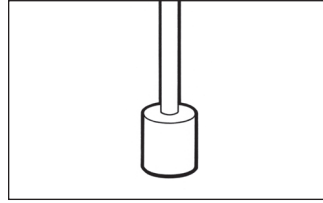

Place magnetic heat sink over the welded plate.

WARNING

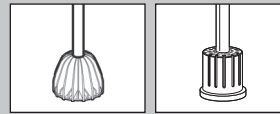

20 seconds

45 seconds

Keep heat sink in place for 20 to 45 seconds depending on magnet style while assembly cools.

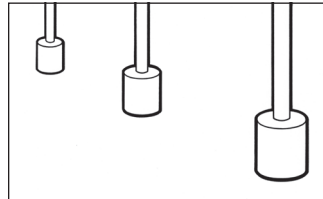

Repeat process for each plate.

IMPORTANT TIP

To increase your pace, work across the sheet, moving heat sinks from one row to the next as you need them.

RHINO BOND WELD TEST

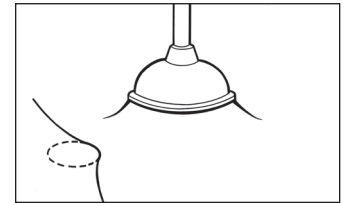

To determine if a weld has been made, place the plunger next to a welded plate and create enough suction to lift the membrane. A weld will create the membrane as shown. If the assembly is not welded, the membrane will lift up from the plate.

Mark any plates that are not welded as a reminder to complete the weld.

THE RHINO BOND DISPLAY

DISPLAY FUNCTIONS

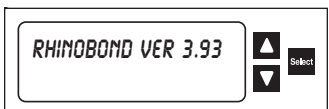

STARTUP SCREEN displays current RhinoBond software version for 3 seconds.

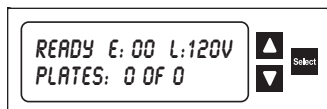

READY SCREEN displays energy level, power voltage and number of plate welds completed. At startup, energy and welds completed reads: 0.

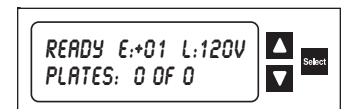
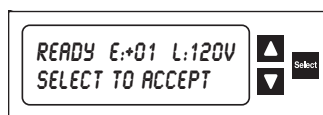
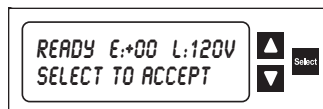

READY SCREEN returns once new energy setting is accepted.

▲ and ▼ increase or decrease energy setting one step at a time (+1 for more energy, -1 for less energy). Press **Select** to accept new setting.

MENU OPTIONS/FEATURES

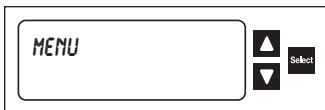

PRESS Select KEY to activate the Menu. Then press ▲ or ▼ to scroll through Menu options.

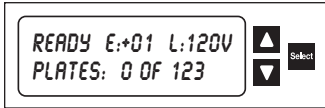
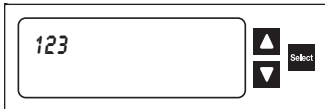

OPTION: ENTER # OF PLATES allows you to record the number of plates for the total job. Press **Select** to activate the option. Press ▲ or ▼ to enter the first digit. Press **Select** to accept and move to the next digit. Repeat until full number is entered and accepted. Press **Select** again to exit.



PLATES REMAINING allows you to view the number of plates which have not been welded for a particular job.

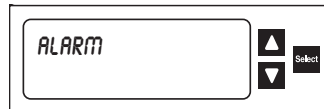

OPTION: SET ALARM activates an alarm that signals the end of a completed weld. Press **Select** to activate the option. Press ▲ or ▼ to choose Alarm On or Alarm Off mode. Press **Select** to accept the mode and exit.

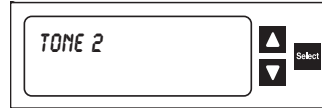
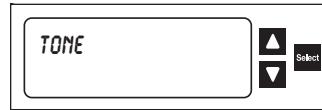

OPTION: SET TONE offers two tone options, to help you distinguish between two RhinoBond units used in close proximity. Press **Select** to activate the option. Press ▲ or ▼ to choose Tone 1 or Tone 2. Press **Select** to accept the tone and exit.

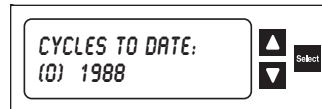

OPTION: CYCLES TO DATE displays the number of cycles completed to date. Cycles are automatically recorded for maintenance and repair purposes. Press **Select** to view Cycles to Date and again to exit.

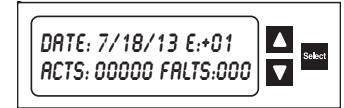
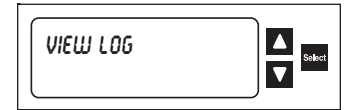

OPTION: VIEW LOG allows a foreman to review the date and details of each event/job. The energy level setting is displayed along with the number of Activations and Faults at the energy level used. Contact OMG for additional information when troubleshooting a job.

ERROR MESSAGES

IMPORTANT

If an error occurs during activation, the display will indicate one of the following error messages.

Allow the target assembly to cool completely, check all connections, realign the tool, and activate the weld again. **WAIT AT LEAST 5 MINUTES BEFORE ATTEMPTING TO ACTIVATE THE WELD A SECOND TIME AFTER A FAULT.** The tool can be used to weld other assemblies while waiting for the assembly to cool.



LOW LINE VOLTAGE. CORRECT SOURCE: Check voltage at your source. Your power may be diminished if:

- Your cord is too long.
- Your power source is inadequate or overloaded.
- The Auto-throttle is on. Turn it off.



HIGH LINE VOLTAGE. CORRECT SOURCE: Correct voltage at your source using an AC Line Voltage Regulator.



NO PLATE FOUND: RhinoBond tool is not centered properly over the plate.



OVERLOAD: RhinoBond senses excessive metal. The tool may be too close to the metal deck or foil faced insulation. Try activating the tool while it is pointed toward the sky.

EC DECLARATION OF CONFORMITY

This is the Manufacturer's Declaration of Conformity which declares that the RhinoBond Induction Welding Tool, model number(s) listed below, complies with the essential health and safety requirements of the European Community Directives, including the latest amendments, as provided below.

Machine Description: RhinoBond® Induction Welding Tool
Model #: RB3
Item #: RBT005
Manufactured by: OMG Roofing Products, Inc.
Directive(s): Low Voltage Directive (LVD) 2006/95/EC

The following harmonized standards were applied:

- **LVD** EN60335-1:2012 +A11 (2014)
EN60335-2-45:2002 +A2 (2012)

RhinoBond® Induction Welding Tools wielding the CE Mark comply with these harmonized standards.
Date of first use: January, 2015.



1 March 2015

Signed: _____ Date: _____
Name: Chris Mader Position: Codes Engineer, OMG Roofing Products

Authorized responsible person to compile the technical file, established in Europe:

Mrs. Dianne Cowley
Laicon Consulting Services Ltd
300 Pennistone Road
Sheffield S5 1UJ England

RhinoBond®
INDUCTION FASTENING SYSTEM

OMG Roofing Products
153 Bowles Road, Agawam, MA 01001 USA
800-633-3800 413-789-0252
www.rhinobond.com